

ASSP For Power Supply Applications (Secondary battery)

DC/DC Converter IC for Charging

MB3878

■ DESCRIPTION

The MB3878 is a DC/DC converter IC suitable for down-conversion, using pulse-width (PWM) charging and enabling output voltage to be set to any desired level from one cell to four cells.

These ICs can dynamically control the secondary battery's charge current by detecting a voltage drop in an AC adaptor in order to keep its power constant (dynamically-controlled charging).

The charging method enables quick charging, for example, with the AC adaptor during operation of a notebook PC. The MB3878 provides a broad power supply voltage range and low standby current as well as high efficiency, making it ideal for use as a built-in charging device in products such as notebook PC.

This product is covered by US Patent Number 6,147,477.

■ FEATURES

- Detecting a voltage drop in the AC adaptor and dynamically controlling the charge current (Dynamically-controlled charging)
- Output voltage setting using external resistor : 1 cell to 4 cells
- High efficiency : 94 %
- Wide range of operating supply voltages : 7 V to 25 V
- Output voltage setting accuracy : $4.2V \pm 0.8%$ (per cell)
- Built-in frequency setting capacitor enables frequency setting using external resistor only
- Oscillator frequency range : 100kHz to 500kHz

(Continued)

■ PACKAGE

24-pin plastic SSOP

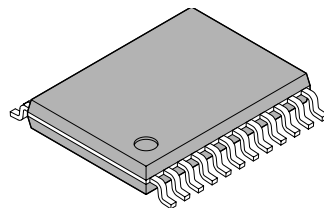

(FPT-24P-M03)

MB3878

(Continued)

- Built-in current detector amplifier with wide in-phase input voltage range : 0 V to V_{cc}
- In standby mode, leave output voltage setting resistor open to prevent inefficient current loss
- Built-in standby current function : 0 μ A (standard)
- Built-in soft-start function
- Built-in totem-pole output stage supporting P-channel MOS FETs devices

■ PIN ASSIGNMENT

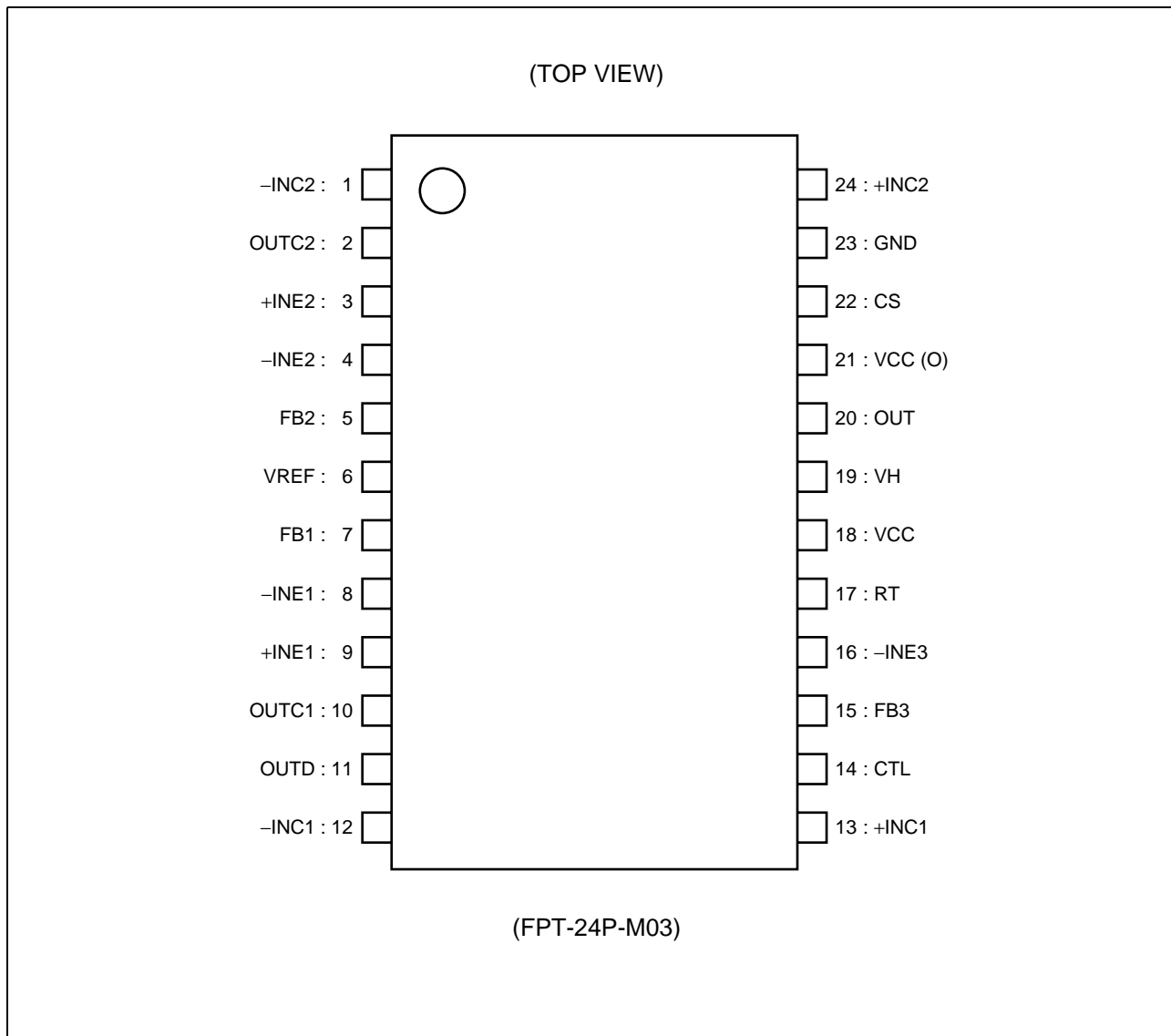

■ PIN DESCRIPTION

Pin No.	Symbol	I/O	Descriptions
1	-INC2	I	Current detection amplifier (Current Amp. 2) input pin.
2	OUTC2	O	Current detection amplifier (Current Amp. 2) output pin.
3	+INE2	I	Error amplifier (Error Amp. 2) non-inverted input pin.
4	-INE2	I	Error amplifier (Error Amp. 2) inverted input pin.
5	FB2	O	Error amplifier (Error Amp. 2) output pin.
6	VREF	O	Reference voltage output pin.
7	FB1	O	Error amplifier (Error Amp. 1) output pin.
8	-INE1	I	Error amplifier (Error Amp. 1) inverted input pin
9	+INE1	I	Error amplifier (Error Amp. 3) non-inverted input pin.
10	OUTC1	O	Current detection amplifier (Current Amp. 1) output pin.
11	OUTD	O	With IC in standby mode, this pin is left open to prevent loss of current through output voltage setting resistance. Set CTL pin to "H" level and OUTD pin to "L" level.
12	-INC1	I	Current detector amplifier (Current Amp. 1) input pin.
13	+INC1	I	Current detector amplifier (Current Amp. 1) input pin.
14	CTL	I	Power supply control pin. Setting the CTL pin low places the IC in the standby mode.
15	FB3	O	Error amplifier (Error Amp. 3) output pin.
16	-INE3	I	Error amplifier (Error Amp. 3) inverted input pin.
17	RT	—	Triangular-wave oscillation frequency setting resistor connection pin.
18	VCC	—	Power supply pin for reference power supply and control circuit.
19	VH	O	Power supply pin for FET drive circuit (VH = Vcc - 5 V).
20	OUT	O	High-side FET gate drive pin.
21	VCC (O)	—	Output circuit power supply pin.
22	CS	—	Soft-start capacitor connection pin.
23	GND	—	Ground pin.
24	+INC2	I	Current detection amplifier (Current Amp. 2) input pin.

MB3878

■ BLOCK DIAGRAM

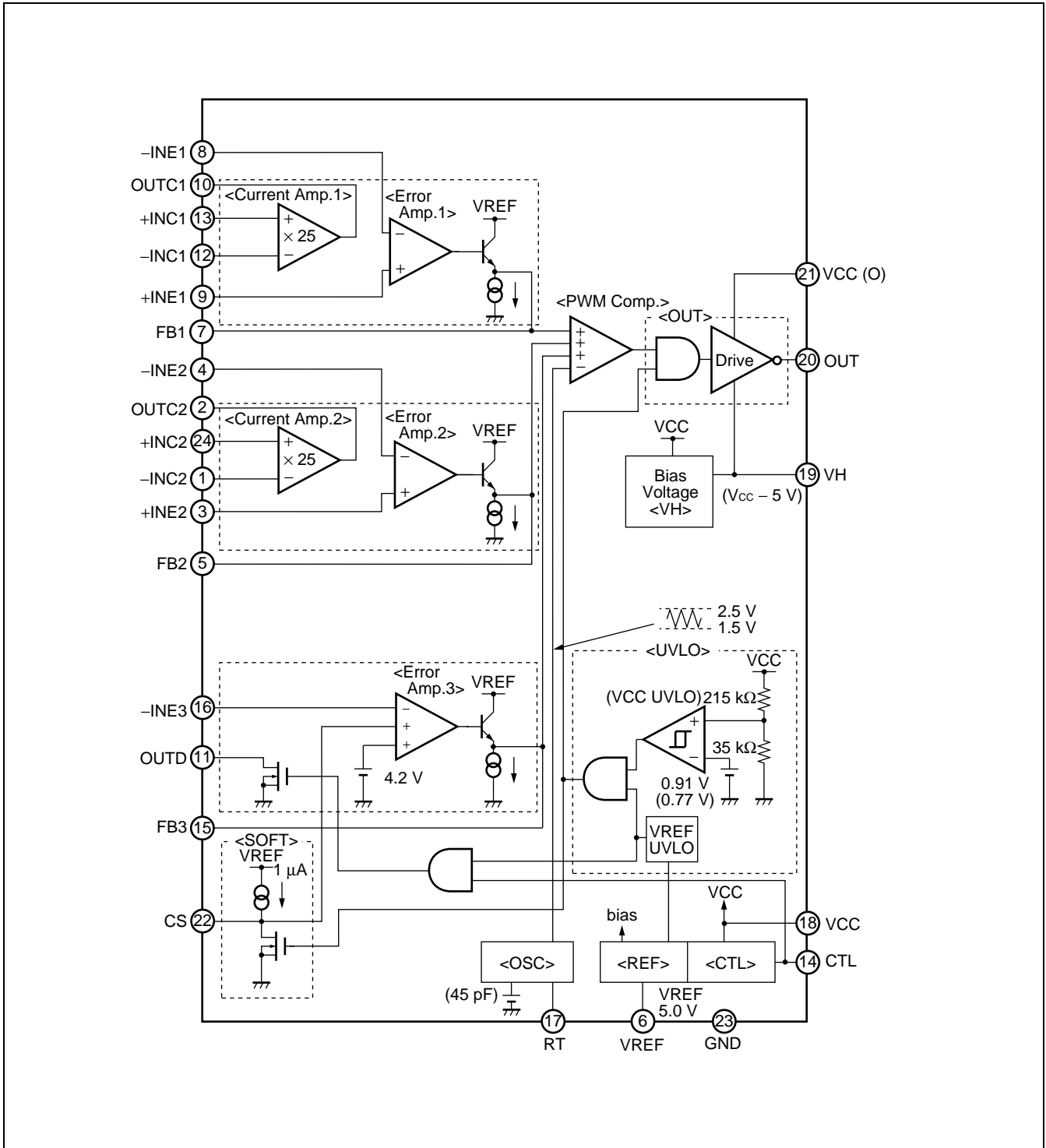

■ ABSOLUTE MAXIMUM RATINGS

Parameter	Symbol	Conditions	Rating		Unit
			Min	Max	
Power supply voltage	V _{CC}	V _{CC} , V _{CC} (O)	—	28	V
Output current	I _{OUT}	—	—	60	mA
Peak output current	I _{OUT}	Duty ≤ 5 % (t = 1 / f _{osc} × Duty)	—	500	mA
Power dissipation	P _D	T _a ≤ +25 °C	—	740*	mW
Storage temperature	T _{stg}	—	-55	+125	°C

* : The package is mounted on the dual-sided epoxy board (10 cm × 10 cm).

WARNING: Semiconductor devices can be permanently damaged by application of stress (voltage, current, temperature, etc.) in excess of absolute maximum ratings. Do not exceed these ratings.

■ RECOMMENDED OPERATING CONDITIONS

Parameter	Symbol	Conditions	Value			Unit
			Min	Typ	Max	
Power supply voltage	V _{CC}	V _{CC} , V _{CC} (O)	7	—	25	V
Reference voltage output current	I _{REF}	—	-1	—	0	mA
VH pin output current	I _{VH}	—	0	—	30	mA
Input voltage	V _{INE}	-INE1 to -INE3, +INE1, +INE2	0	—	V _{CC} - 1.8	V
	V _{INC}	+INC1, +INC2, -INC1, -INC2	0	—	V _{CC}	V
OUTD pin output voltage	V _{OUTD}	—	0	—	17	V
OUTD pin output current	I _{OUTD}	—	0	—	2	mA
CTL pin input voltage	V _{CTL}	—	0	—	25	V
output current	I _{OUT}	—	-45	—	45	mA
Peak output current	I _{OUT}	Duty ≤ 5 % (t = 1 / f _{osc} × Duty)	-450	—	450	mA
Oscillator frequency	f _{osc}	—	100	290	500	kHz
Timing resistor	R _T	—	33	47	130	kΩ
Soft-start capacitor	C _S	—	—	2200	100000	pF
VH pin capacitor	C _{VH}	—	—	0.1	1.0	μF
Reference voltage output capacitor	C _{REF}	—	—	0.1	1.0	μF
Operating ambient temperature	T _a	—	-30	+25	+85	°C

WARNING: The recommended operating conditions are required in order to ensure the normal operation of the semiconductor device. All of the device's electrical characteristics are warranted when the device is operated within these ranges.

Always use semiconductor devices within their recommended operating condition ranges. Operation outside these ranges may adversely affect reliability and could result in device failure.

No warranty is made with respect to uses, operating conditions, or combinations not represented on the data sheet. Users considering application outside the listed conditions are advised to contact their FUJITSU representatives beforehand.

■ ELECTRICAL CHARACTERISTICS

(Ta = +25 °C, VCC = 19 V, VCC (O) = 19 V, VREF = 0 mA)

Parameter		Symbol	Pin No.	Conditions	Value			Unit
					Min	Typ	Max	
Reference voltage block (Ref)	Output voltage	V _{REF}	6	Ta = +25 °C	4.995	5.000	5.045	V
				Ta = -30 °C to +85 °C	4.945	5.000	5.055	V
	Input stability	Line	6	VCC = 7 V to 25 V	—	3	10	mV
	Load stability	Load	6	VREF = 0 mA to -1 mA	—	1	10	mV
	Short-circuit output current	I _{OS}	6	VREF = 1 V	-25	-15	-5	mA
Under voltage lockout protection circuit block (UVLO)	Threshold voltage	V _{TLH}	18	VCC = VCC (O) , VCC = $\overline{\downarrow}$	6.1	6.4	6.7	V
		V _{THL}	18	VCC = VCC (O) , VCC = $\overline{\uparrow}$	5.1	5.4	5.7	V
	Hysteresis width	V _H	18	VCC = VCC (O)	0.7	1.0	1.3	V
	Threshold voltage	V _{TLH}	6	VREF = $\overline{\downarrow}$	2.6	2.8	3.0	V
		V _{THL}	6	VREF = $\overline{\uparrow}$	2.4	2.6	2.8	V
Hysteresis width	V _H	6	V _H = V _{TLH} - V _{THL}	0.05	0.20	0.35	V	
Soft-start block (SOFT)	Charge current	I _{CS}	22	—	-1.3	-0.8	-0.5	μA
Triangular waveform oscillator circuit block (OSC)	Oscillation frequency	f _{OSC}	20	RT = 47 kΩ	260	290	320	kHz
	Frequency temperature stability	Δf/fdt	20	Ta = -30 °C to +85 °C	—	1*	—	%
Error amplifier block (Error Amp.1, Error Amp.2)	Input offset voltage	V _{IO}	3, 4, 8, 9	FB1 = FB2 = 2 V	—	1	5	mV
	Input bias current	I _B	3, 4, 8, 9	—	-100	-30	—	nA
	Common mode input voltage range	V _{CM}	3, 4, 8, 9	—	0	—	V _{CC} - 1.8	V
	Voltage gain	A _V	5, 7	DC	—	100*	—	dB
	Frequency bandwidth	B _W	5, 7	A _V = 0 dB	—	2.0*	—	MHz
	Output voltage	V _{FBH}	5, 7	—	4.7	4.9	—	V
		V _{FBL}	5, 7	—	—	20	200	mV
	Output source current	I _{SOURCE}	5, 7	FB1 = FB2 = 2 V	—	-2.0	-0.6	mA
Output sink current	I _{SINK}	5, 7	FB1 = FB2 = 2 V	150	300	—	μA	

* : Standard design value.

(Continued)

(Ta = +25 °C, VCC = 19 V, VCC (O) = 19 V, VREF = 0 mA)

Parameter	Symbol	Pin No.	Conditions	Value			Unit	
				Min	Typ	Max		
Error amplifier block (Error Amp.3)	Threshold voltage	V _{TH1}	16	FB3 = 2 V, Ta = +25 °C	4.167	4.200	4.233	V
		V _{TH2}	16	FB3 = 2 V, Ta = -30 °C to +85 °C	4.158	4.200	4.242	V
	Input current	I _{INE3}	16	-INE3 = 0 V	-100	-30	—	nA
	Voltage gain	A _v	15	DC	—	100*	—	dB
	Frequency bandwidth	B _w	15	A _v = 0 dB	—	2.0*	—	MHz
	Output voltage	V _{FBH}	15	—	4.7	4.9	—	V
		V _{FBL}	15	—	—	20	200	mV
	Output source current	I _{SOURCE}	15	FB3 = 2 V	—	-2.0	-0.6	mA
	Output sink current	I _{SINK}	15	FB3 = 2 V	150	300	—	μA
	OUTD pin output leak current	I _{LEAK}	11	OUTD = 16.8 V	—	0	1	μA
OUTD pin output ON resistor	R _{ON}	11	OUTD = 1 mA	—	70	100	Ω	
Current detection amplifier block (Current Amp.1, Current Amp.2)	Input current	I _{-INCH}	13, 24	+INC1 = +INC2 = 12.7 V, -INC1 = -INC2 = 12.6 V	—	10	20	μA
		I _{-INCH}	1, 12	+INC1 = +INC2 = 12.7 V, -INC1 = -INC2 = 12.6 V	—	0.1	0.2	μA
		I _{-INCL}	13, 24	+INC1 = +INC2 = 0.1 V, -INC1 = -INC2 = 0 V	-130	-65	—	μA
		I _{-INCL}	1, 12	+INC1 = +INC2 = 0.1 V, -INC1 = -INC2 = 0 V	-140	-70	—	μA
	Current detection voltage	V _{OUTC1}	2, 10	+INC1 = +INC2 = 12.7 V, -INC1 = -INC2 = 12.6 V	2.25	2.5	2.75	V
		V _{OUTC2}	2, 10	+INC1 = +INC2 = 12.63 V, -INC1 = -INC2 = 12.6 V	0.50	0.75	1.00	V
		V _{OUTC3}	2, 10	+INC1 = +INC2 = 0.1 V, -INC1 = -INC2 = 0 V	1.25	2.50	3.75	V
		V _{OUTC4}	2, 10	+INC1 = +INC2 = 0.03 V, -INC1 = -INC2 = 0 V	0.125	0.750	1.375	V
	Common mode input voltage range	V _{CM}	1, 12, 13, 24	—	0	—	V _{CC}	V
	Voltage gain	A _v	2, 10	+INC1 = +INC2 = 12.7 V, -INC1 = -INC2 = 12.6 V	22.5	25	27.5	V/V
Frequency bandwidth	B _w	2, 10	A _v = 0 dB	—	2.0*	—	MHz	

* : Standard design value.

(Continued)

MB3878

(Continued)

(Ta = +25 °C, VCC = 19 V, VCC (O) = 19 V, VREF = 0 mA)

Parameter	Symbol	Pin No.	Conditions	Value			Unit	
				Min	Typ	Max		
Current detection amplifier block (Current Amp.1, Current Amp.2)	Output voltage	V _{OUTCH}	2, 10	—	4.7	4.9	—	V
		V _{OUTCL}	2, 10	—	—	20	200	mV
	Output source current	I _{SOURCE}	2, 10	OUTC1 = OUTC2 = 2 V	—	-2.0	-0.6	mA
	Output sink current	I _{SINK}	2, 10	OUTC1 = OUTC2 = 2 V	150	300	—	μA
PWM comparator block (PWM Comp.)	Threshold voltage	V _{TL}	5, 7, 15	Duty cycle = 0 %	1.4	1.5	—	V
		V _{TH}	5, 7, 15	Duty cycle = 100 %	—	2.5	2.6	V
Output block (OUT)	Output source current	I _{SOURCE}	20	OUT = 11 V, Duty ≤ 5 % (t = 1 / f _{osc} × Duty)	—	-200*	—	mA
	Output sink current	I _{SINK}	20	OUT = 16 V, Duty ≤ 5 % (t = 1 / f _{osc} × Duty)	—	200*	—	mA
	Output ON resistor	R _{OH}	20	OUT = -45 mA	—	8.0	12.0	Ω
		R _{OL}	20	OUT = 45 mA	—	6.5	9.7	Ω
	Rise time	tr1	20	OUT = 3300 pF (equivalent to Si4435 × 1)	—	70*	—	ns
Fall time	tf1	20	OUT = 3300 pF (equivalent to Si4435 × 1)	—	60*	—	ns	
Control block (CTL)	CTL input voltage	V _{ON}	14	Active mode	2	—	25	V
		V _{OFF}	14	Standby mode	0	—	0.8	V
	Input current	I _{CTLH}	14	CTL = 5 V	—	100	200	μA
		I _{CTL}	14	CTL = 0 V	—	0	1	μA
Bias voltage block (VH)	Output voltage	V _H	19	VCC = VCC (O) = 7 V to 25 V, VH = 0 to 30 mA	V _{CC} - 5.5	V _{CC} - 5.0	V _{CC} - 4.5	V
General	Standby current	I _{CCS}	18, 19	VCC = VCC (O) , CTL = 0 V	—	0	10	μA
	Power supply current	I _{CC}	18, 19	VCC = VCC (O) , CTL = 5 V	—	8.0	12.0	mA

* : Standard design value

■ TYPICAL CHARACTERISTICS

Power supply current vs. power supply voltage

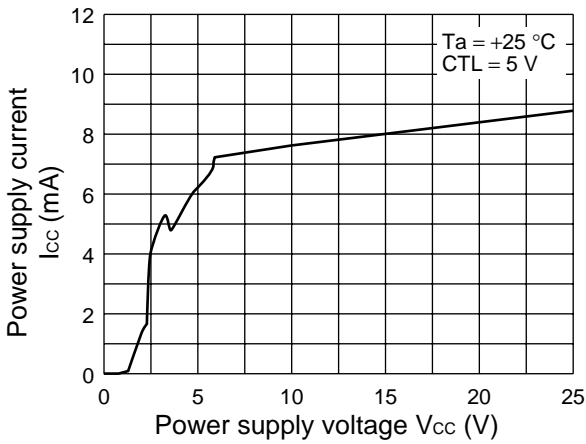

Reference voltage vs. power supply voltage

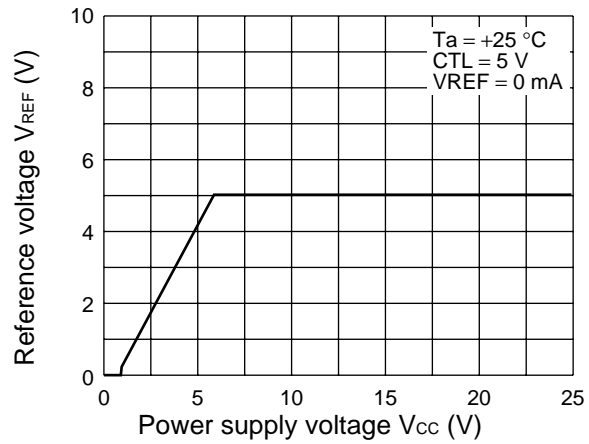

Reference voltage vs. VREF load current

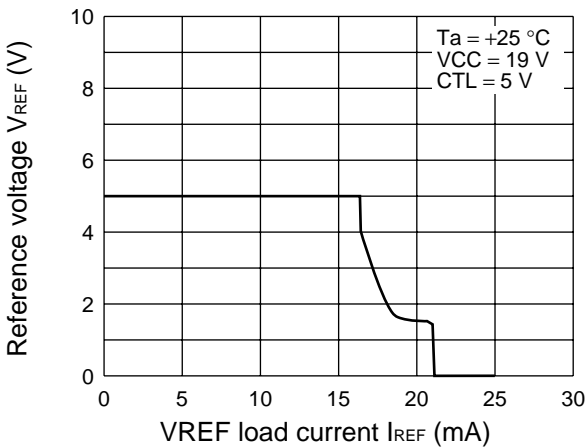

Reference voltage vs. ambient temperature

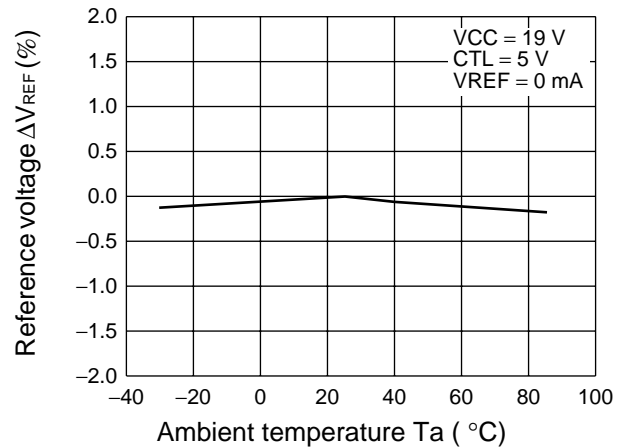

Reference voltage vs. CTL pin voltage

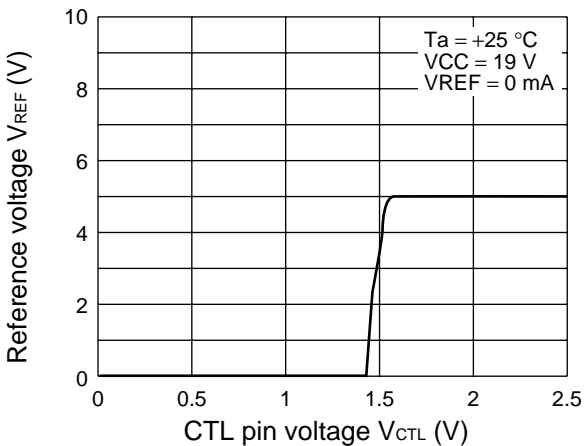

CTL pin current vs. CTL pin voltage

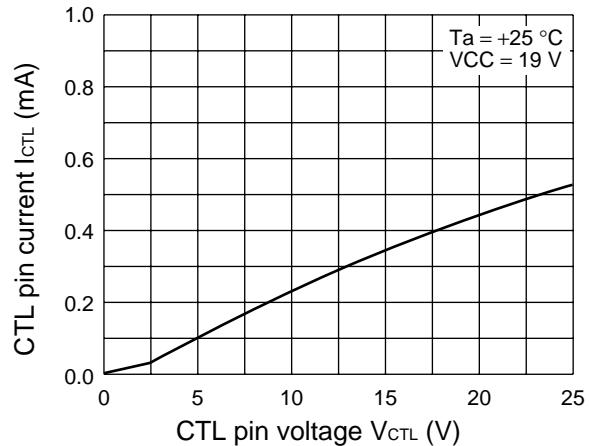

(Continued)

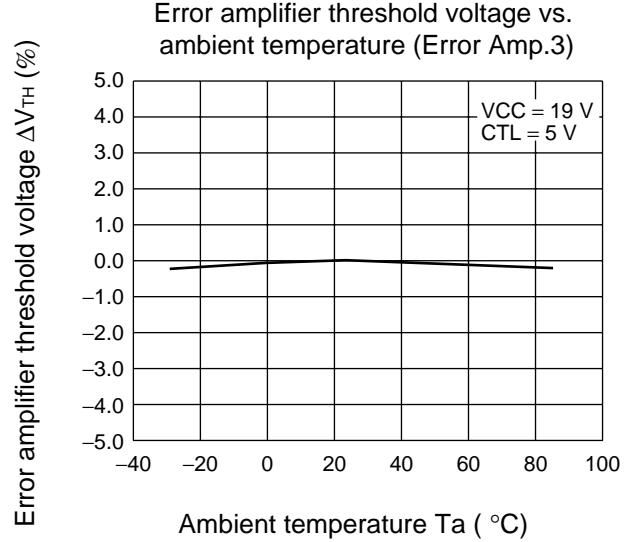
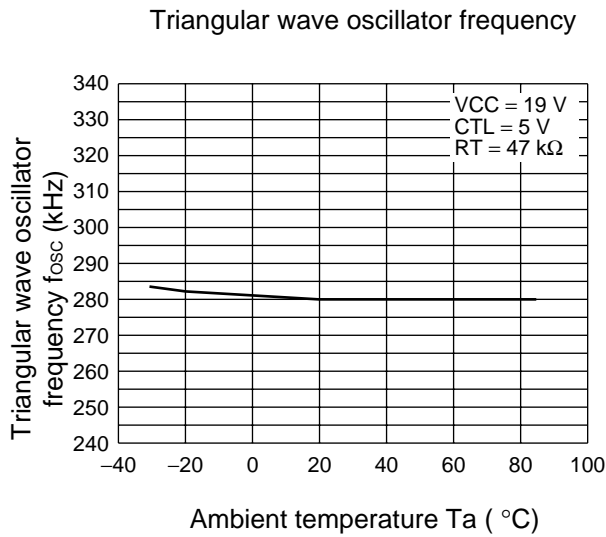
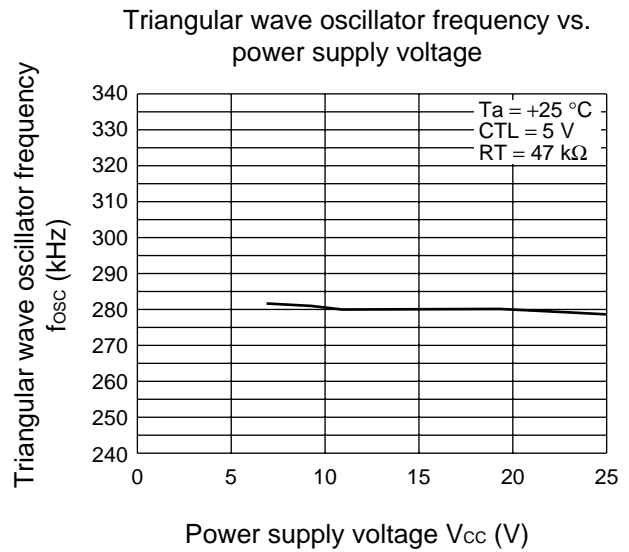
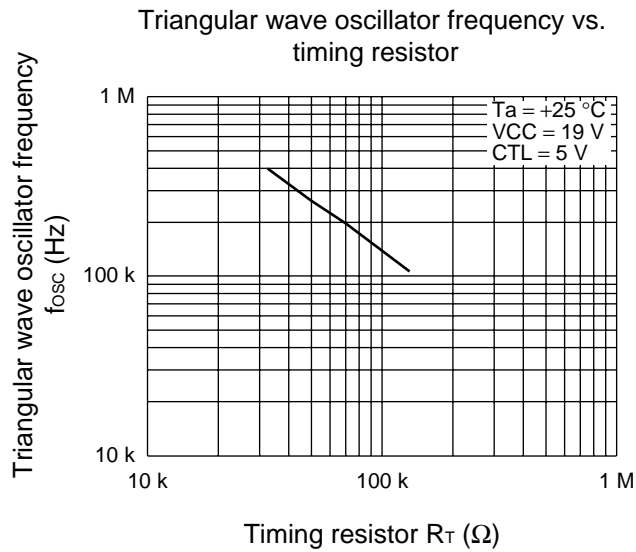

(Continued)

(Continued)

Error amplifier gain and phase vs. frequency

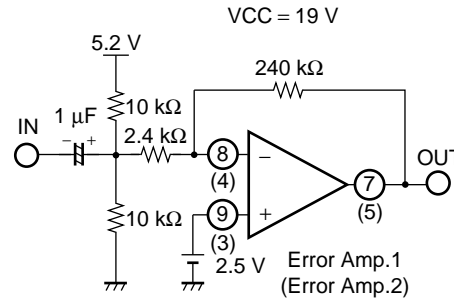
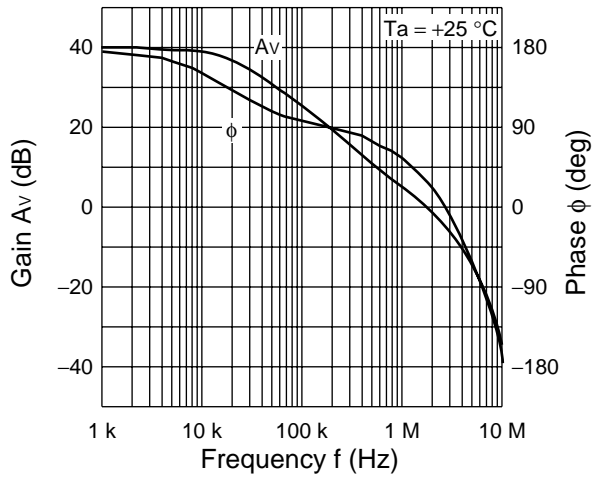

Current detection amplifier gain and phase vs. frequency

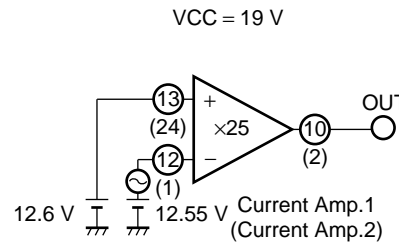
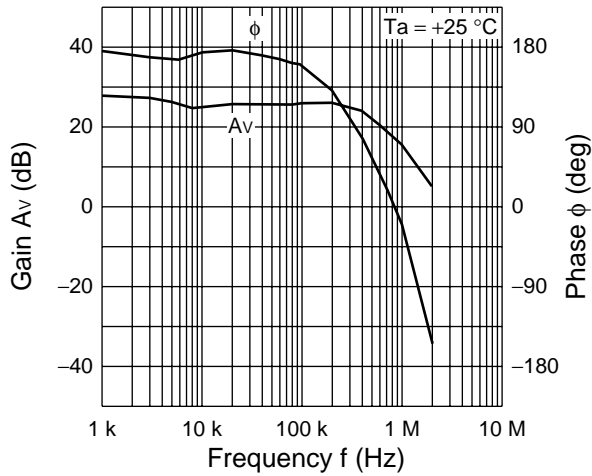

Power dissipation vs. ambient temperature

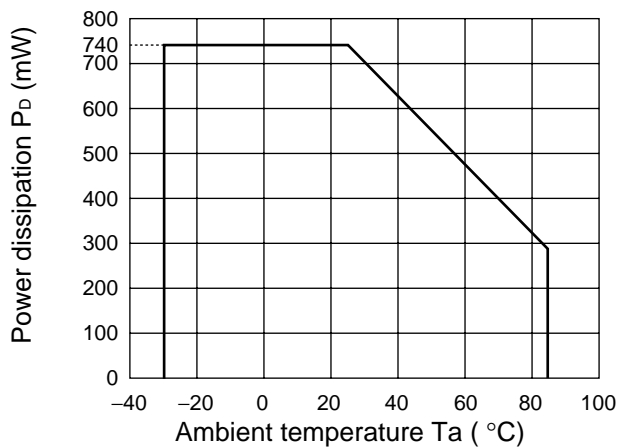

■ FUNCTIONAL DESCRIPTION

1. DC/DC Converter Unit

(1) Reference voltage block (Ref)

The reference voltage generator uses the voltage supplied from the VCC terminal (pin 18) to generate a temperature-compensated, stable voltage (5.0V Typ) used as the reference supply voltage for the IC's internal circuitry.

This pin can also be used to obtain a load current to a maximum of 1mA from the reference voltage VREF terminal (pin 6).

(2) Triangular wave oscillator block (OSC)

The triangular wave oscillator builds the capacitor for frequency setting into, and generates the triangular wave oscillator waveform by connecting the frequency setting resistor with the RT terminal (pin 17).

The triangular wave is input to the PWM comparator on the IC.

(3) Error amplifier block (Error Amp.1)

This amplifier detects the output signal from the current detector amplifier (Current amp .1), compares this to the +INE1 terminal (pin 9), and outputs a PWM control signal to be used in controlling the charging current.

In addition, an arbitrary loop gain can be set up by connecting a feedback resistor and capacitor between the FB1 terminal (pin 7) and -INE terminal (pin 8), providing stable phase compensation to the system.

(4) Error amplifier block (Error Amp.2)

This amplifier (Error Amp.2) detects voltage dependency of the AC adaptor and outputs a PWM control signal.

In addition, an arbitrary loop gain can be set by connecting a feedback resistor and capacitor from the FB2 terminal (pin 5) to the -INE2 terminal (pin 4) of the error amplifier, enabling stable phase compensation to the system.

(5) Error amplifier block (Error Amp.3)

This error amplifier (Error Amp. 3) detects the output voltage from the DC/DC converter and outputs the PWM control signal. External output voltage setting resistors can be connected to the error amplifier inverse input pin to set the desired level of output voltage from 1 cell to 4 cells.

In addition, an arbitrary loop gain can be set by connecting a feedback resistor and capacitor from the FB3 terminal (pin 15) to the -INE3 terminal (pin 16) of the error amplifier, enabling stable phase compensation to the system.

Connecting a soft-start capacitor to the CS terminal (pin 22) prevents surge currents when the IC is turned on. Using an error amplifier for soft-start detection makes the soft-start time constant, independent of the output load.

(6) Current detector amplifier block (Current Amp.1)

The current detection amplifier (Current Amp.1) detects a voltage drop which occurs between both ends of the output sense resistor (R_s) due to the flow of the charge current, using the +INC1 terminal (pin 13) and -INC1 terminal (pin 12). Then it outputs the signal amplified by 25 times to the error amplifier (Error Amp.1) at the next stage.

(7) PWM comparator block (PWM Comp.)

The PWM comparator circuit is a voltage-pulse width converter for controlling the output duty of the error amplifiers (Error Amp. 1 to Error Amp. 3) depending on their output voltage.

The PWM comparator circuit compares the triangular wave generated by the triangular wave oscillator to the error amplifier output voltage and turns on the external output transistor during the interval in which the triangular wave voltage is lower than the error amplifier output voltage.

(8) Output block (OUT)

The output circuit uses a totem-pole configuration capable of driving an external P-channel MOS FET.

The output “L” level sets the output amplitude to 5 V (Typ) using the voltage generated by the bias voltage block (VH).

This results in increasing conversion efficiency and suppressing the withstand voltage of the connected external transistor in a wide range of input voltages.

(9) Control block (CTL)

Setting the CTL terminal (pin 14) low places the IC in the standby mode. (The supply current is 10 μ A at maximum in the standby mode.)

(10) Bias voltage block (VH)

The bias voltage circuit outputs $V_{cc} - 5$ V (Typ) as the minimum potential of the output circuit. In the standby mode, this circuit outputs the potential equal to V_{cc} .

2. Protection Functions

Under voltage lockout protection circuit (UVLO)

The transient state or a momentary decrease in supply voltage or internal reference voltage (VREF), which occurs when the power supply is turned on, may cause malfunctions in the control IC, resulting in breakdown or degradation of the system. To prevent such malfunction, the under voltage lockout protection circuit detects a supply voltage or internal reference voltage drop and fixes the OUT terminal (pin 20) to the “H” level. The system restores voltage supply when the supply voltage or internal reference voltage reaches the threshold voltage of the under voltage lockout protection circuit.

3. Soft-start Function

Soft-start block (SOFT)

Connecting a capacitor to the CS terminal (pin 22) prevents surge currents when the IC is turned on. Using an error amplifier for soft-start detection makes the soft-start time constant, independent of the output load of the DC/DC converter.

■ SETTING THE CHARGING VOLTAGE

The charging voltage (DC/DC output voltage) can be set by connecting external voltage setting resistors (R3, R4) to the -INE3 terminal. Be sure to select a resistor value that allows you to ignore the on resistor (70 Ω, 1 mA) of the internal FET connected to the OUTD terminal (pin 11).

Battery charging voltage: V_o

$$V_o (V) = (R3 + R4) / R4 \times 4.2 (V)$$

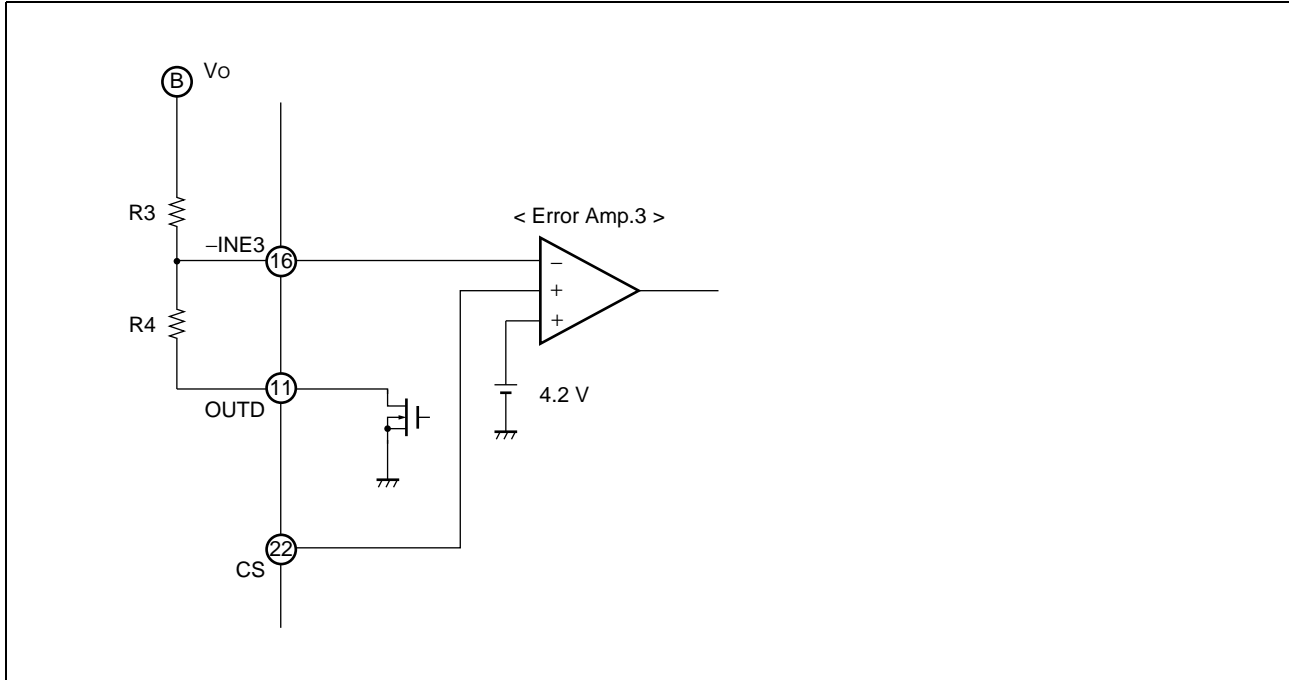

■ METHOD OF SETTING THE CHARGING CURRENT

The charge current (output control current) value can be set with the voltage at the +INE1 terminal (pin 9).

If a current exceeding the set value attempts to flow, the charge voltage drops according to the set current value.

Battery charge current setting voltage : +INE1

$$+INE1 (V) = 25 \times I1 (A) \times R_s (\Omega)$$

■ METHOD OF SETTING THE SOFT-START TIME

Upon activation, the IC starts charging the capacitor (Cs) connected to the CS terminal (pin 22).

The error amplifier causes soft-start operation to be performed with the output voltage in proportion to the CS terminal voltage regardless of the load current of the DC/DC converter.

Soft-start time: t_s (Time taken for the output voltage to reach 100 %)

$$t_s (s) \approx 4.2 \times C_s (\mu F)$$

■ METHOD OF SETTING THE TRIANGULAR WAVE OSCILLATOR FREQUENCY

The triangular wave oscillator frequency can be set by the timing resistor (R_T) connected the RT terminal (pin 17).

Triangular wave oscillator frequency: f_{osc}

$$f_{osc} (kHz) \approx 13630 / R_T (k\Omega)$$

■ AC ADAPTOR VOLTAGE DETECTION

With an external resistor connected to the +INE2 terminal(pin 3), the IC enters the dynamically-controlled charging mode to reduce the charge current to keep AC adaptor power constant when the partial potential point A of the AC adaptor voltage (Vcc) becomes lower than the voltage at the -INE2 terminal.

AC adaptor detected voltage setting: Vth

$$V_{th} (V) = (R1 + R2) / R2 \times -INE2$$

-INE2 setting voltage range : 1.176 V to 4.2 V (equivalent to 7 V to 25 V for Vcc)

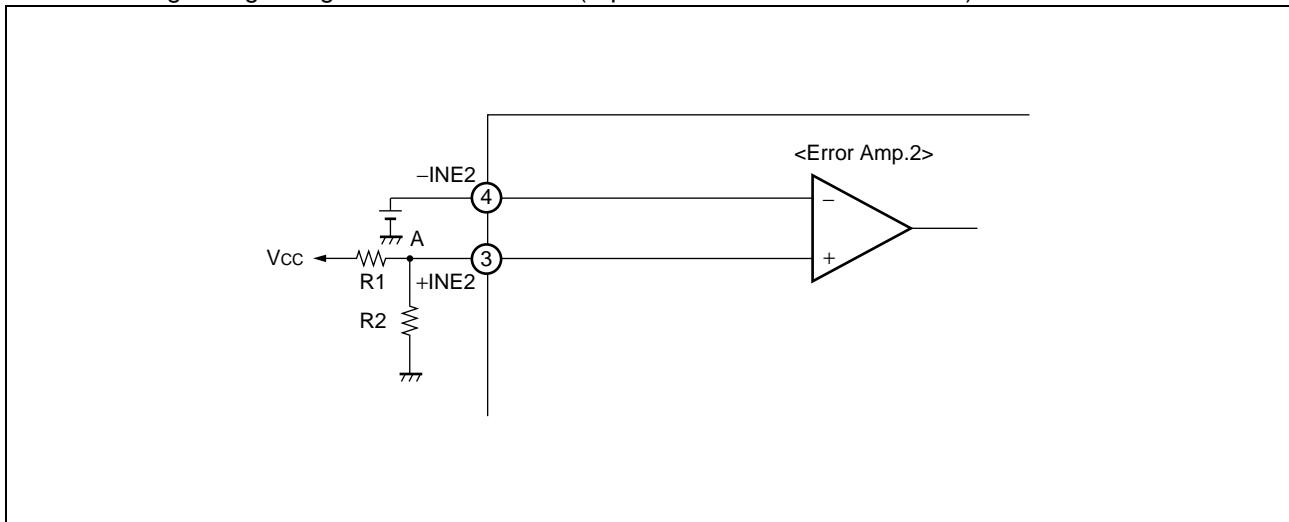

■ OPERATION TIMING DIAGRAM

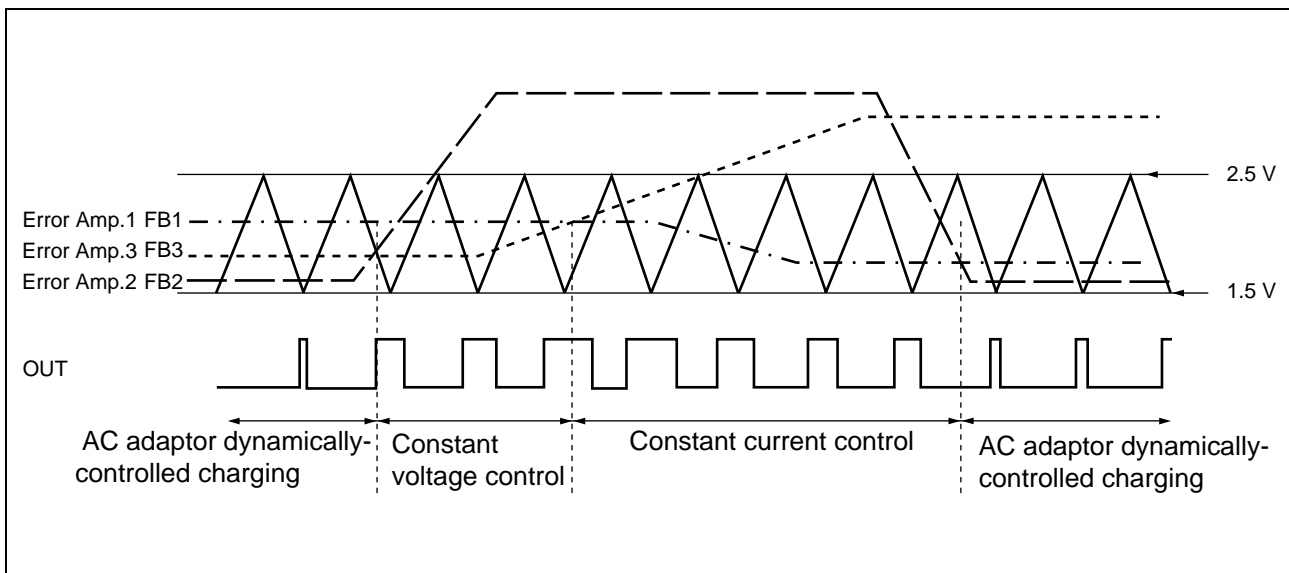

■ PROCESSING WITHOUT USE OF THE CS PIN

If the soft-start function is not used, the CS terminal (pin 22) should be left open.

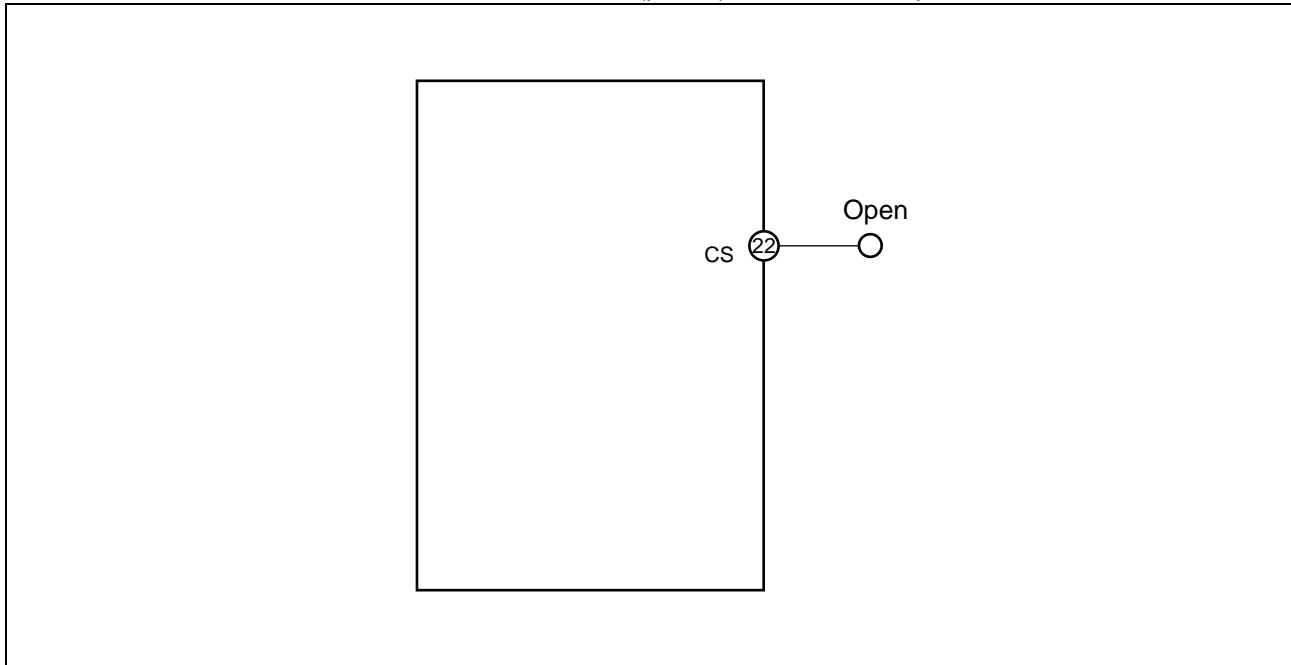

When no soft-start time is specified.

■ NOTE ON AN EXTERNAL REVERSE-CURRENT PREVENTIVE DIODE

- Insert a reverse-current preventive diode at one of the three locations marked * to prevent reverse current from the battery.
- When selecting the reverse current prevention diode, be sure to consider the reverse voltage (V_R) and reverse current (I_R) of the diode.

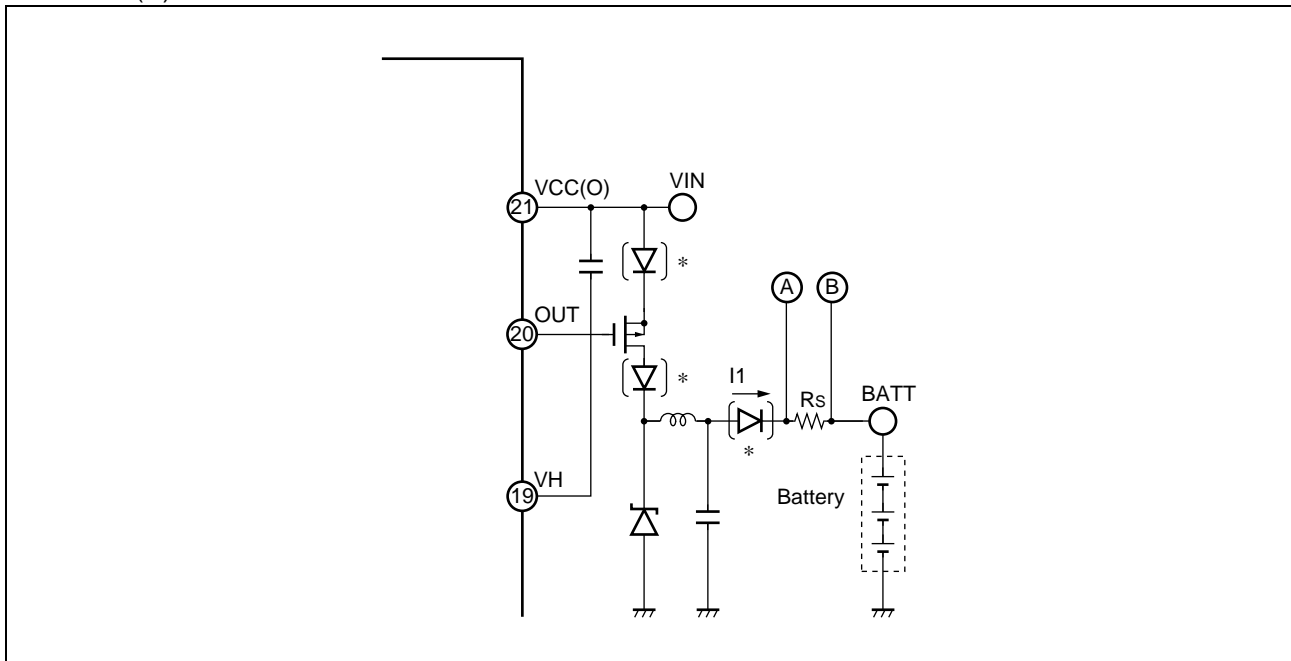

APPLICATION EXAMPLE 1

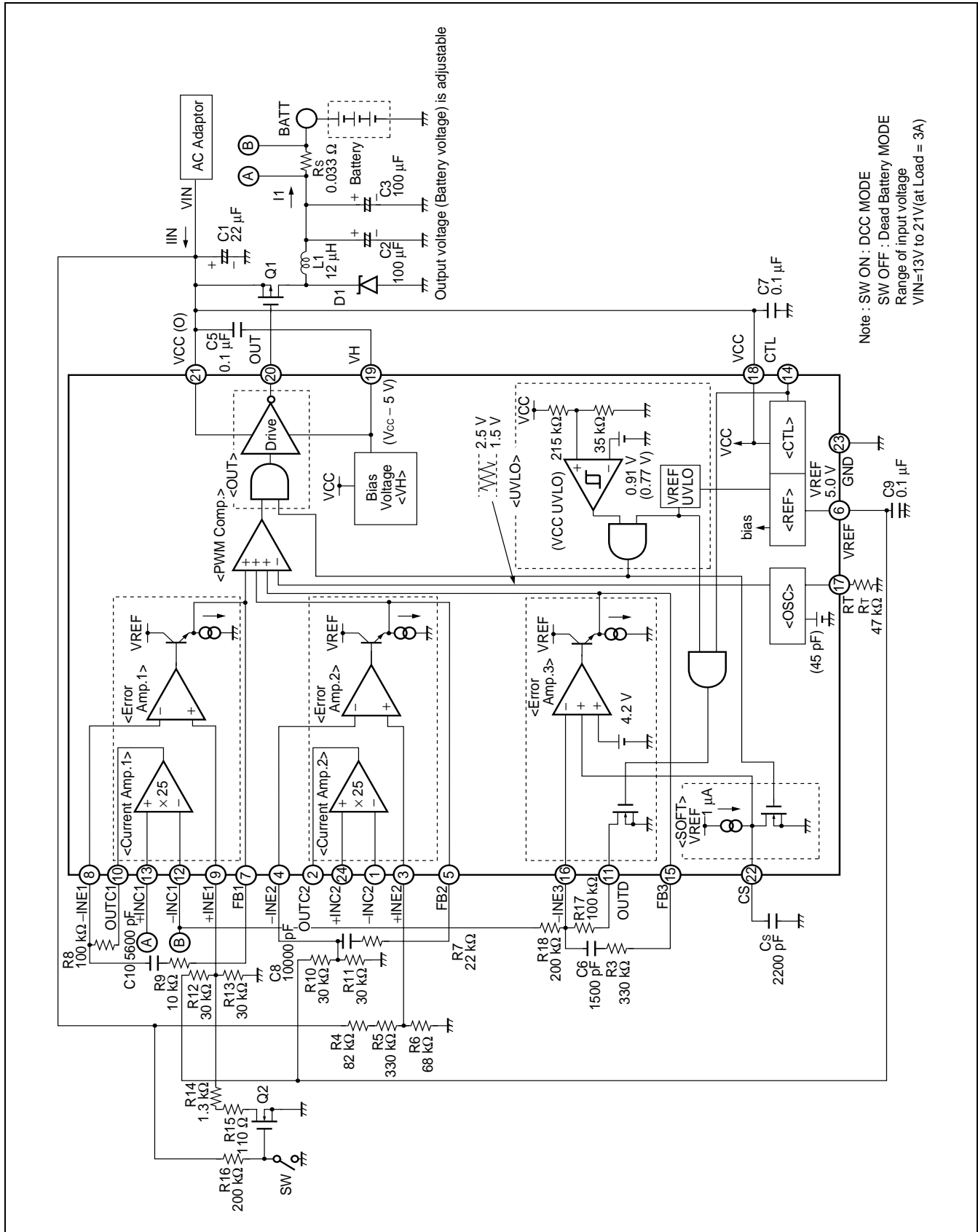

MB3878

■ PARTS LIST (for APPLICATION EXAMPLE 1)

COMPONENT	ITEM	SPECIFICATION		VENDOR	PARTS No.
Q1 Q2	FET FET	Si4435DY 2N7002		VISHAY SILICONIX VISHAY SILICONIX	Si4435DY 2N7002
D1	Diode	MBRS130LT3		MOTOROLA	MBRS130LT3
L1	Coil	12 μ H	4.0 A, 38 m Ω	SUMIDA	CDRH124-12 μ H
C1 C2, C3 Cs C5 C6 C7 C8 C9 C10	OS Condenser OS Condenser Ceramics Condenser Ceramics Condenser Ceramics Condenser Ceramics Condenser Ceramics Condenser Ceramics Condenser Ceramics Condenser Ceramics Condenser	22 μ F 100 μ F 2200 pF 0.1 μ F 1500 pF 0.1 μ F 10000 pF 0.1 μ F 5600 pF	25 V (10 %) 25 V (10 %) 10 % 16 V 10 % 25 V 10 % 16 V 10 %	—	—
Rs Rr R3 R4 R5 R6 R7 R8 R9 R10 to R13 R14 R15 R16 R17 R18	Resistor Resistor Resistor Resistor Resistor Resistor Resistor Resistor Resistor Resistor Resistor Resistor Resistor Resistor Resistor Resistor	0.033 Ω 47 k Ω 330 k Ω 82 k Ω 330 k Ω 68 k Ω 22 k Ω 100 k Ω 10 k Ω 30 k Ω 1.3 k Ω 110 Ω 200 k Ω 100 k Ω 200 k Ω	1.0 % 1.0 % 1.0 % 0.5 % 0.5 % 0.5 % 1.0 % 1.0 % 1.0 % 0.5 % 0.5 % 0.5 % 5 % 0.5 % 0.5 %	—	—

Note VISHAY SILICONIX : VISHAY Intertechnology, Inc.

MOTOROLA : Motorola Japan Ltd.

SUMIDA : SUMIDA ELECTRIC CO., Ltd.

REFERENCE DATA

Conversion efficiency vs. charge current
(Fixed voltage mode)

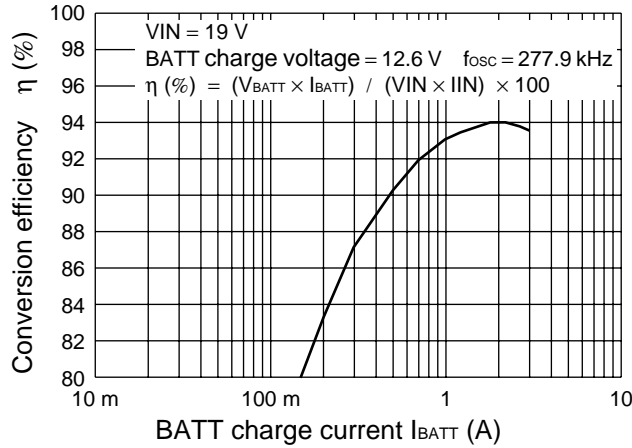

Conversion efficiency vs. charge voltage
(Fixed current mode)

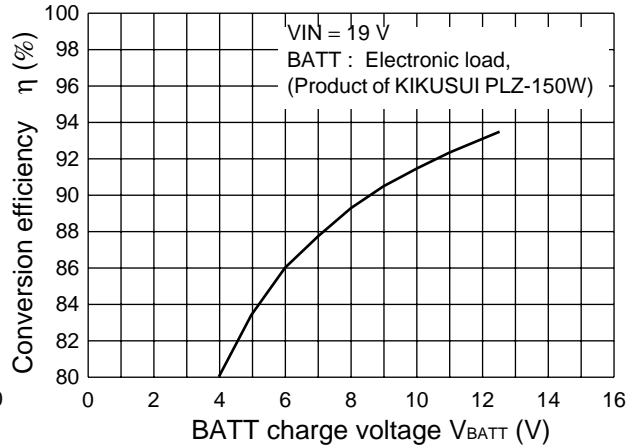

BATT voltage vs. BATT charge current

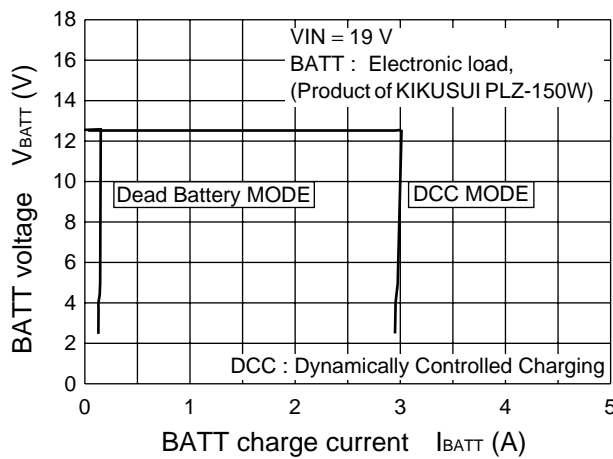

Soft-start operating waveforms

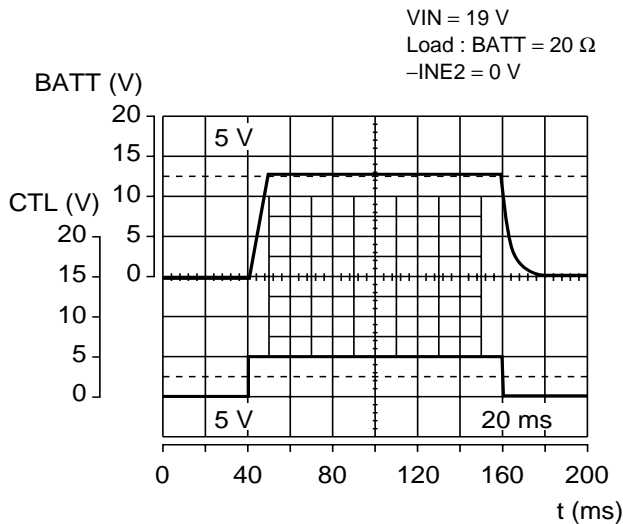

DC/DC converter switching waveforms

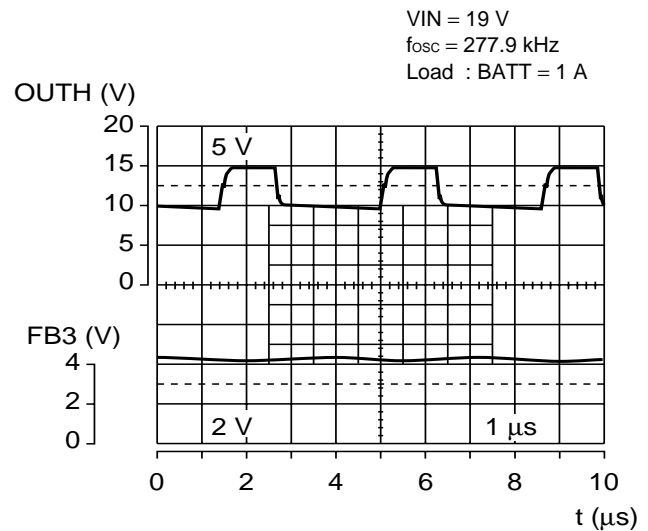

APPLICATION EXAMPLE 2

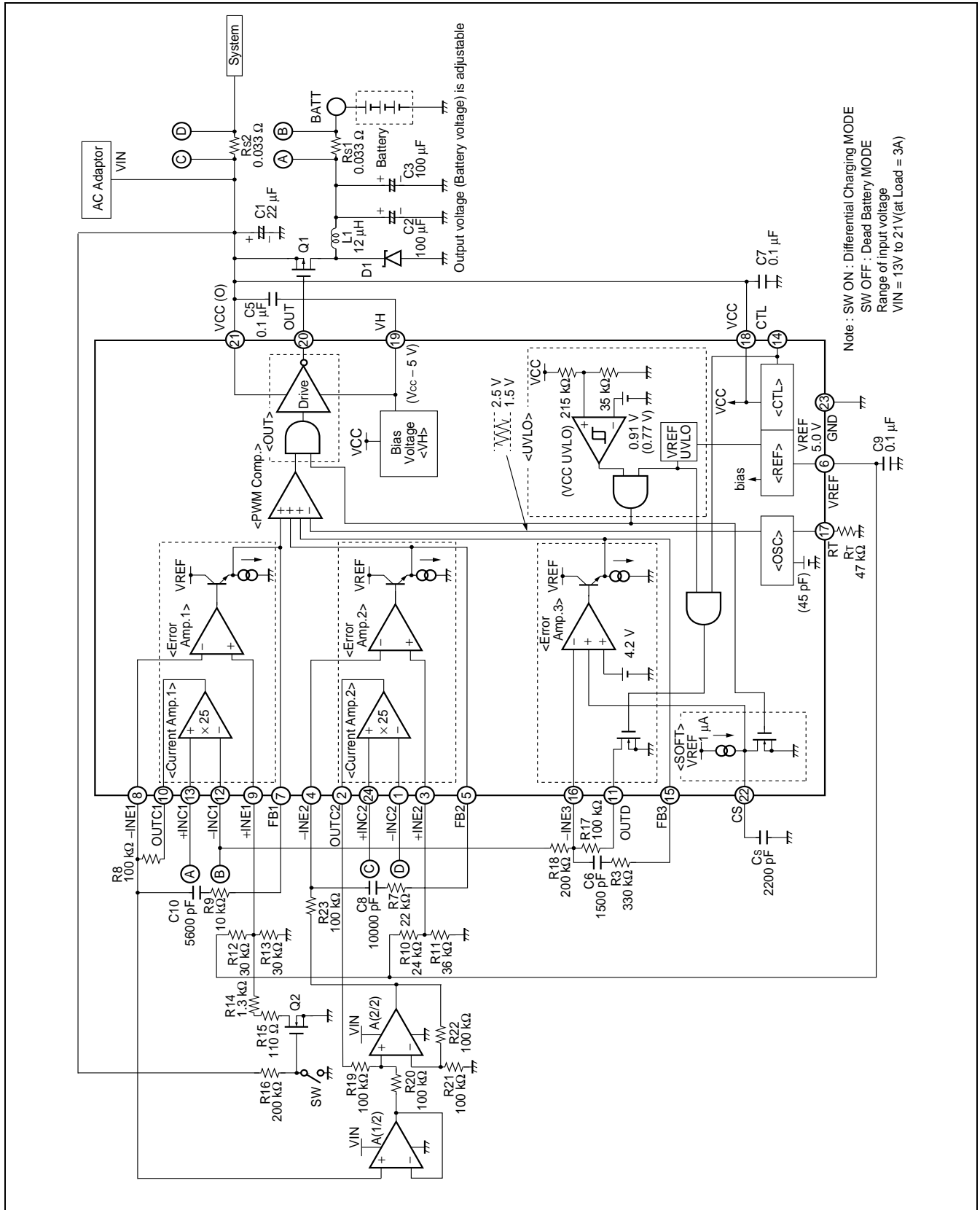

■ PARTS LIST (for APPLICATION EXAMPLE 2)

COMPONENT	ITEM	SPECIFICATION		VENDOR	PARTS No.
Q1	FET	Si4435DY		VISHAY SILICONIX	Si4435DY
Q2	FET	2N7002		VISHAY SILICONIX	2N7002
D1	Diode	MBRS130LT3		MOTOROLA	MBRS130LT3
A	Dual Op-amp	MB47358		Our Company	MB47358
L1	Coil	12 μ H	4.0 A, 38 m Ω	SUMIDA	CDRH124-12 μ H
C1	OS Condenser	22 μ F	25 V (10 %)	—	—
C2, C3	OS Condenser	100 μ F	25 V (10 %)		
Cs	Ceramics Condenser	2200 pF	10 %		
C5	Ceramics Condenser	0.1 μ F	16 V		
C6	Ceramics Condenser	1500 pF	10 %		
C7	Ceramics Condenser	0.1 μ F	25 V		
C8	Ceramics Condenser	10000 pF	10 %		
C9	Ceramics Condenser	0.1 μ F	16 V		
C10	Ceramics Condenser	5600 pF	10 %		
R _{S1} , R _{S2}	Resistor	0.033 Ω	1.0 %		
R _T	Resistor	47 k Ω	1.0 %		
R3	Resistor	330 k Ω	1.0 %		
R7	Resistor	22 k Ω	1.0 %		
R8	Resistor	100 k Ω	1.0 %		
R9	Resistor	10 k Ω	1.0 %		
R10	Resistor	36 k Ω	0.5 %		
R11	Resistor	27 k Ω	0.5 %		
R12, R13	Resistor	30 k Ω	0.5 %		
R14	Resistor	1.3 k Ω	0.5 %		
R15	Resistor	110 Ω	0.5 %		
R16	Resistor	200 k Ω	5 %		
R17	Resistor	100 k Ω	1.0 %		
R18	Resistor	200 k Ω	0.5 %		
R19, R20	Resistor	100 k Ω	1.0 %		
R21, R22	Resistor	100 k Ω	0.5 %		
R23	Resistor	100 k Ω	1.0 %		

Note VISHAY SILICONIX : VISHAY Intertechnology, Inc.
MOTOROLA : Motorola Japan Ltd.
SUMIDA : SUMIDA ELECTRIC CO., Ltd.

MB3878

■ USAGE PRECAUTIONS

• Printed circuit board ground lines should be set up with consideration for common impedance.

• Take appropriate static electricity measures.

- Containers for semiconductor materials should have anti-static protection or be made of conductive material.
- After mounting, printed circuit boards should be stored and shipped in conductive bags or containers.
- Work platforms, tools, and instruments should be properly grounded.
- Working personnel should be grounded with resistance of 250 k Ω to 1 M Ω between body and ground.

• Do not apply negative voltages.

The use of negative voltages below -0.3 V may create parasitic transistors on LSI lines, which can cause abnormal operation

■ ORDERING INFORMATION

Part number	Package	Remarks
MB3878PFV	24-pin plastic SSOP (FPT-24P-M03)	

■ PACKAGE DIMENSION

24-pin plastic SSOP
(FPT-24P-M03)

Note1: Pins width and pins thickness include plating thickness.
Note2: * This dimension does not include resin protrusion.

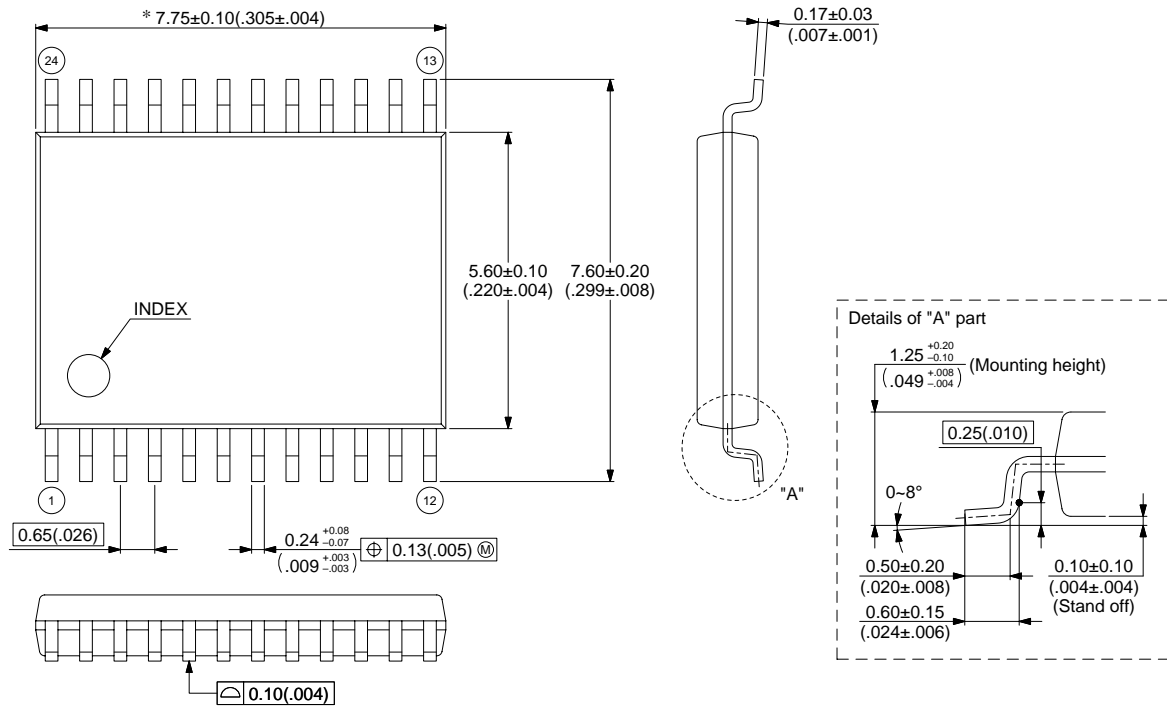

© 2001 FUJITSU LIMITED F24018S-c-3-4

Dimensions in mm (inches)

FUJITSU LIMITED

All Rights Reserved.

The contents of this document are subject to change without notice. Customers are advised to consult with FUJITSU sales representatives before ordering.

The information and circuit diagrams in this document are presented as examples of semiconductor device applications, and are not intended to be incorporated in devices for actual use. Also, FUJITSU is unable to assume responsibility for infringement of any patent rights or other rights of third parties arising from the use of this information or circuit diagrams.

The products described in this document are designed, developed and manufactured as contemplated for general use, including without limitation, ordinary industrial use, general office use, personal use, and household use, but are not designed, developed and manufactured as contemplated (1) for use accompanying fatal risks or dangers that, unless extremely high safety is secured, could have a serious effect to the public, and could lead directly to death, personal injury, severe physical damage or other loss (i.e., nuclear reaction control in nuclear facility, aircraft flight control, air traffic control, mass transport control, medical life support system, missile launch control in weapon system), or (2) for use requiring extremely high reliability (i.e., submersible repeater and artificial satellite).

Please note that Fujitsu will not be liable against you and/or any third party for any claims or damages arising in connection with above-mentioned uses of the products.

Any semiconductor devices have an inherent chance of failure. You must protect against injury, damage or loss from such failures by incorporating safety design measures into your facility and equipment such as redundancy, fire protection, and prevention of over-current levels and other abnormal operating conditions.

If any products described in this document represent goods or technologies subject to certain restrictions on export under the Foreign Exchange and Foreign Trade Law of Japan, the prior authorization by Japanese government will be required for export of those products from Japan.

F0209

© FUJITSU LIMITED Printed in Japan